

# XONE:32 BLOCK DIAGRAM

## STEREO INPUTS

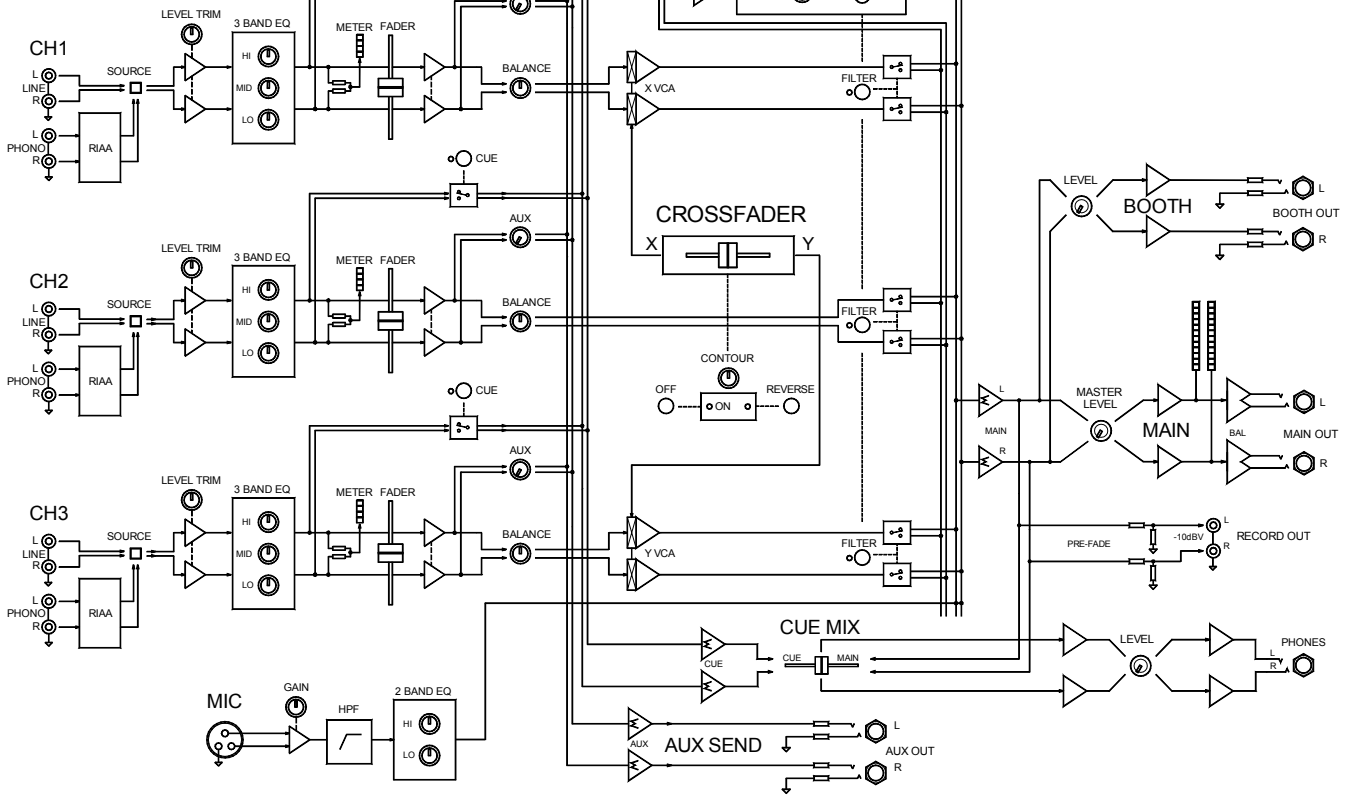

**USER PRESETS**

1	CH FILTER ON/OFF
2	FILTER TYPE
3	LFO ON/OFF
4	X 2 ON/OFF

STORE AND RECALL THE FOLLOWING:

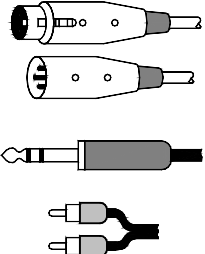

## Connector Types

XLR connector : Pin 2 = hot (+) Pin 3 = cold (-) Pin 1 = GND  
 TRS input and output connectors : Tip = hot (+) Ring = cold (-) Sleeve = GND  
 RCA PHONO pin connectors

## Input Connections

	Type	Impedance	Sensitivity
MIC IN	Balanced XLR female	2k ohm	-45 to -15dBu
Stereo LINE IN	RCA phono	>10k ohm	-15 to +15dBu
Stereo PHONO IN	RCA phono RIAA	47kohm/330pF	2 to 100mV

## Output Connections

	Type	Impedance	Level
MIX OUT L,R	Electronically balanced TRS jack	<75 ohm	0dBu
BOOTH OUT L,R	Impedance balanced TRS jack	<75 ohm	-2dBu
AUX OUT L,R	Impedance balanced TRS jack	<75 ohm	-2dBu
RECORD OUT L,R	RCA phono	<600 ohm	-10dBV
HEADPHONES	Tip = L Ring = R	30 to 600 ohm, 70 ohms recommended	